

SHARP

LH15306A

ISSUE: Feb.08,2017

To ; _____

Product Name Laser Diode

Model No. GH04W10A2GC

※These specifications contain 8 pages including the cover and appendix.
If you have any objections, please contact us before issuing purchasing order.

Accepted by:

By: _____
Name: _____
Title: _____
Date: _____

By: _____
Name: _____
Title: _____
Date: _____

Sharp Corporation

By: M. Sakata
Name: Masahiko Sakata
Title: Division Manager
Development Div. I
Lighting Business Unit
Electronic Components And Devices BU
Date: Feb.08,2017

Reviewed by:
By: Hiroshi Nakatsu
Name: Hiroshi Nakatsu
Title: Senior Manager
Date: Feb.08,2017

Prepared by:
By: Kenichi Kurita
Name: Kenichi Kurita
Title: SuperVisor
Date: Feb.08,2017

Product name : Laser Diode

Model No. : GH04W10A2GC

1. These specification sheets include materials protected under copyright of Sharp Corporation ("Sharp"). Please handle with great care and do not reproduce or cause anyone to reproduce them without Sharp's consent.
2. When using this Sharp product, please observe the absolute maximum ratings, other conditions and instructions for use described in the specification sheets, as well as the precautions mentioned below.
Sharp assumes no responsibility for any damages resulting from use of the product which does not comply with absolute maximum ratings, other conditions and instructions for use included in the specification sheets, and the precautions mentioned below.

(Precautions)

- (1) In making catalogue or instruction manual based on the specification sheets, please verify the validity of the catalogue or instruction manuals after assembling Sharp products in customer's products at the responsibility of customer.
- (2) This Sharp product is designed for use in the following application areas ;
 - Computers • OA equipment • Telecommunication equipment (Terminal) • Measuring equipment
 - Tooling machines • Audio visual equipment • Home appliancesIf the use of the Sharp product in the above application areas is for equipment listed in paragraphs (3) or (4), please be sure to observe the precautions given in those respective paragraphs.
- (3) Appropriate measures, such as fail-safe design and redundant design considering the safety design of the overall system and equipment, should be taken to ensure reliability and safety when Sharp product is used for equipment in responsibility of customer which demands high reliability and safety in function and precision, such as ;
 - Transportation control and safety equipment (aircraft, train, automobile etc.)
 - Traffic signals • Gas leakage sensor breakers • Rescue and security equipment
 - Other safety equipment
- (4) Sharp product is designed for consumer goods and controlled as consumer goods in production and quality. Please do not use this product for equipment which require extremely high reliability and safety in function and precision, such as ;
 - Space equipment • Telecommunication equipment (for trunk lines)
 - Nuclear power control equipment • Medical equipment
- (5) Please contact and consult with a Sharp sales representative if there are any question regarding interpretation of the above four paragraphs.

3. Disclaimer

The warranty period for Sharp product is one (1) year (or six (6) months in case of generalized product) after shipment. During the period, if there are any products problem, Sharp will repair (if applicable), replace or refund. Except the above, both parties will discuss to cope with the problems.

The failed Sharp product after the above one (1) year (or six (6) month for generalized product) period will be coped with by Sharp, provided that both parties shall discuss and determine on sharing responsibility based on the analysis results thereof subject to the above scope of warranty.

The warranty described herein is only for Sharp product itself which are purchased by or delivered to customer. Damages arising from Sharp product malfunction or failure shall be excepted.

Sharp will not be responsible for the Sharp product due to the malfunction or failures thereof which are caused by:

- (1) storage keep trouble during the inventory in the marketing channel.
- (2) intentional act, negligence or wrong/poor handling.
- (3) equipment which Sharp products are connected to or mounted in.
- (4) disassembling, reforming or changing Sharp products.
- (5) installation problem.
- (6) act of God or other disaster (natural disaster, fire, flood, etc.)
- (7) external factors (abnormal voltage, abnormal electromagnetic wave, fire, etc.)
- (8) special environment (factory, coastal areas, hot spring area, etc.)
- (9) phenomenon which cannot be foreseen based on the practical technologies at the time of shipment.
- (10) the factors not included in the product specification sheet.

4. Please contact and consult with a Sharp sales representative for any questions about Sharp product.

Spec No. LH15306A

1. Scope

This specification covers the appearance and characteristics of blue violet Laser Diode,
Model No. GH04W10A2GC

【Outline of this product】

This product is equipped with an InGaN multiple quantum well blue violet laser diode .
Oscillating transverse mode of this model is TE.
Oscillating transverse mode of this model is multi-mode.

- | | |
|--|--|
| 2. Outline Dimensions and Terminal Connections | described in page 3 |
| 3. Ratings and Characteristics | described in page 4 |
| 4. Reliability | described in page 5 |
| 5. Quality level | described in page 6 |
| 6. Supplements | |
| 6-1. ODS materials | described in page 6 |
| 6-2. RoHS compliant product. | described in page 6 |
| 6-3. Information relating to China RoHS. | described in page 6 |
| 6-4. Packing | described in page 7 |
| 6-5. Production place | described on the labels, which are on the clean bag and on the packing case. |
| 7. Operating and handling precautions | described in page 8 |

2. Outline dimensions and Terminal connections

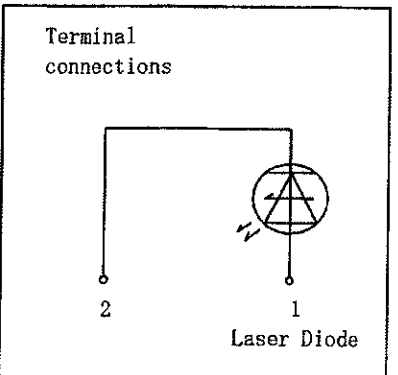
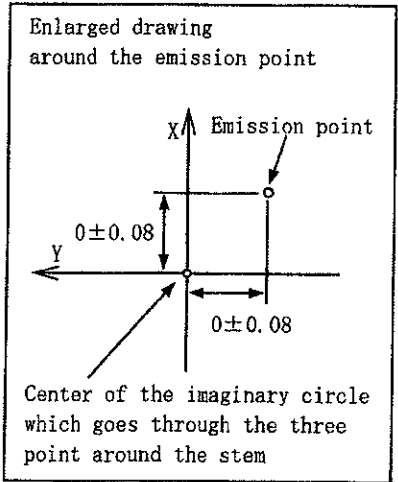
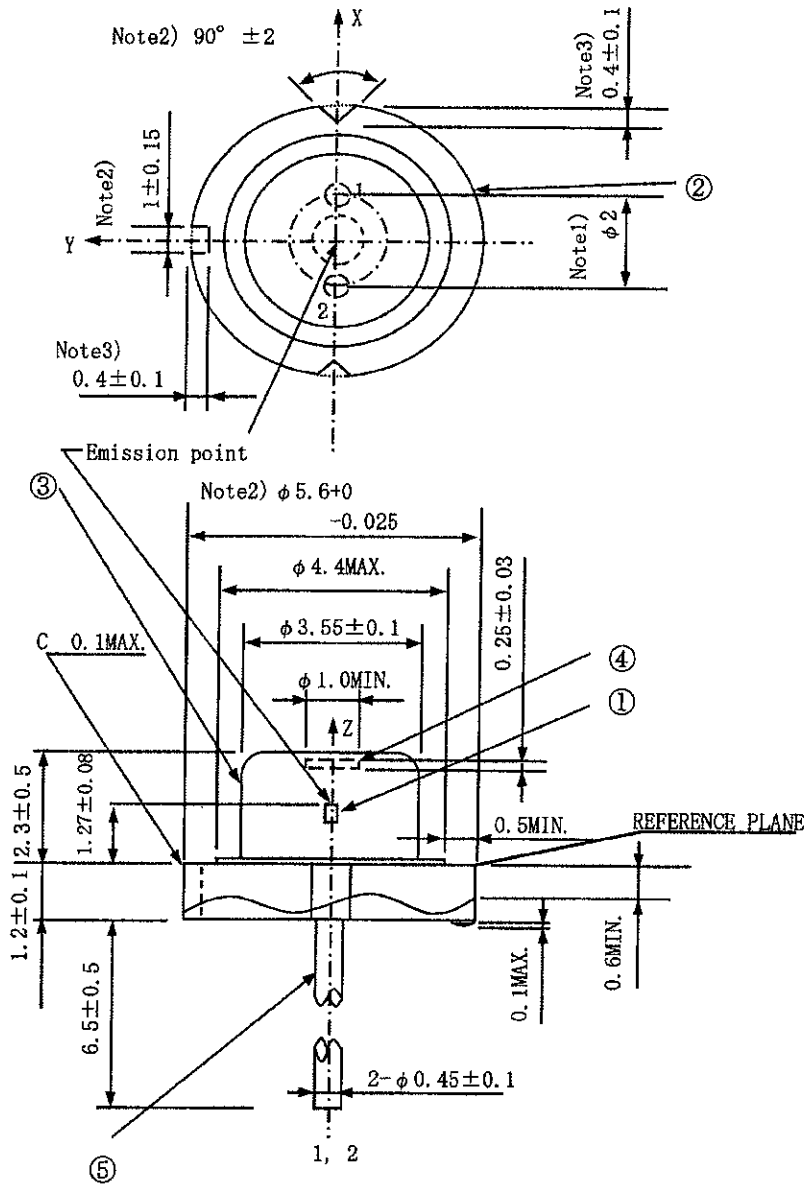

Mass of the product :
0.32g (reference value)

Marking
Position : Side of a cap
Printed contents :
M
 : Production lot

- Note 1) Dimension of the bottom of leads.
 Note 2) These dimensions are valid only in the range of 0 ~ 0.6mm below from the reference plane.
 Note 3) These dimensions are defined from the imaginary circle which goes through the three points around the stem to the bottom of cut off parts.

GENERAL TOLERANCES ± 0.2

UNIT:mm

| No. | Component | Material | Finish |
|-----|------------------|---------------------|---------------|
| ① | Laser Diode Chip | InAlGaN | - |
| ② | Stem | Fe, Cu | Gold-plated |
| ③ | Cap | Kovar | Nickel-plated |
| ④ | Window glass | Borosilicated glass | - |
| ⑤ | Lead pins | Kovar | Gold-plated |

3. Ratings and Characteristics

3-1 Absolute Maximum Ratings

(Tc=25°C (Note 1))

| Parameter | Symbol | Value | Unit | |
|--|----------------|---------|-----------|----|
| Optical power output | CW (Note 2) | Po | 350 | mW |
| | Pulse (Note 3) | Pp | 750 | mW |
| Reverse voltage | Laser diode | Vrl | 2 | V |
| Operating temperature (Case temperature) | CW (Note 2) | Topc(c) | 0 ~ +50 | °C |
| | Pulse (Note 3) | Topp(c) | 0 ~ +50 | °C |
| Storage temperature | | Tstg | -40 ~ +85 | °C |
| Soldering temperature (Note 4) | | Tsld | 350 | °C |

(Note 1) Tc : Case temperature

(Note 2) CW : Continuous Wave Operation

(Note 3) Pulse : Pulse Operation (Pulse Width 0.2 μs Duty:50%)

(Note 4) Soldering temperature means soldering iron tip temperature while soldering.

Soldering position is 1.6mm apart from bottom edge of the case. (Immersion time: ≦3s)

3-2 Electro-optical Characteristics (Note 1)

(Tc=25°C (Note 2))

| Parameter | Symbol | Conditions | Min. | Typ. | Max. | Unit |
|--|---------------------------|-----------------|--|------|------|------|
| Threshold current | Ith | - | - | 140 | 200 | mA |
| Operating current | Iop | Po=300mW | 250 | 325 | 400 | mA |
| Operating voltage | Vop | | - | 4.5 | 5.5 | V |
| Wavelength | λp | | 400 | 406 | 414 | nm |
| 1/e ² Intensity Angle (Parallel) (Note 3, 5) | θ // (1/e ²) | | 8 | 14 | 20 | ° |
| 1/e ² Intensity Angle (Perpendicular) (Note 3, 5) | θ ⊥ (1/e ²) | | 36 | 41 | 48 | ° |
| Misalignment angle (Parallel) (Note 4, 5) | Δθ // (1/e ²) | | -3 | - | 3 | ° |
| Misalignment angle (Perpendicular) (Note 4, 5) | Δθ ⊥ (1/e ²) | | -4 | - | 4 | ° |
| Slope efficiency | ηd | | $\frac{120\text{mW}}{I(300\text{mW}) - I(180\text{mW})}$ | 1.4 | 1.8 | 2.2 |
| Polarization Angle (Note 6) | - | Po=50mW NA=0.13 | -5 | - | 5 | ° |
| Polarization Ratio (Note 6) | Pl | | 100 | - | - | - |
| Pulse operating current (Note 7) | PIop | Pp=700mW | - | - | 700 | mA |
| Difference rate of ηp (Note 8) | Δηp | Pp=50~700mW | - | - | 100 | % |

(Note 1) Initial value, Continuous Wave Operation

(Note 2) Tc:Case temperature

(Note 3) Full angle of 13.5% (≠1/e²) peak intensity(Note 4) Misalignment angle of 13.5% (≠1/e²) peak intensity

(Note 5) Parallel to the junction plane (X-Z plane)

Perpendicular to the junction plane (Y-Z plane)

(Note 6) Reference Standards : JIS-C-5943

(Note 7) Pulse Operation (Pulse Width 0.2 μs Duty:50%)

(Note 8) Difference rate of ηp

Pulse Operation (Pulse Width 0.2 μs Duty:50%)

$$\Delta \eta p = \frac{\eta p_{\text{Max}} - \eta p_{\text{Min}}}{\eta p} \times 100 \quad (\%)$$

$$\eta p = \frac{650\text{mW}}{I_{\text{op}}(700\text{mW}) - I_{\text{op}}(50\text{mW})}$$

ηpMax, ηpMin : maximum value and minimum value of the ηp data measured between Pp=50mW to Pp=700mW (Iop increment of 5mA).

4. Reliability

4-1 The reliability of products satisfy all the items listed below.

Confidence level : 90%

| No. | Test | Test Conditions | Samples:n | Defective:C | LTPD(%) | Failure criteria No. [4-2] |
|-----|---|---|-----------|-------------|---------|----------------------------|
| 1 | Solderability (Note 1) | Soldering temperature: $230 \pm 5^\circ\text{C}$ (Flux used) Immersion time: $5 \pm 0.5\text{s}$ Solder and Flux : Senju Metal Industry M705 and ESR-250 | 11 | 0 | 20 | 4 |
| 2 | Resistance to soldering (Note 1) | Soldering iron tip temperature: $350 \pm 5^\circ\text{C}$ 20W Immersion time: $3+0/-1\text{s}$ | 11 | 0 | 20 | 1, 2, 3 |
| 3 | Terminal strength (Tensile test) | Load: 6N Duration: $5 \pm 1\text{s}$ Once for each terminal | 11 | 0 | 20 | 5 |
| 4 | Terminal strength (Bending test) | Load: 2.5N $0^\circ \sim 90^\circ \sim 0^\circ \sim -90^\circ \sim 0^\circ$ Once for each terminal | 11 | 0 | 20 | 5 |
| 5 | Mechanical shock | Acceleration: 1000m/s^2 Pulse width: 6ms Direction: $\pm X, \pm Y$ and $\pm Z$ Three times for each direction | 11 | 0 | 20 | 1, 2, 3 |
| 6 | Variable frequency vibration | Acceleration: 100m/s^2 or Amplitude: 1.5mm Frequency: 10~500~10Hz 15min reciprocation Direction: X, Y and Z 2 h for each direction | 11 | 0 | 20 | 1, 2, 3 |
| 7 | Temperature cycling | Lower temperature: -40°C Higher temperature: $+85^\circ\text{C}$ Duration: 30min each, 30 times | 11 | 0 | 20 | 1, 2, 3 |
| 8 | airtightness | He leak test $5 \times 10^{-3} \text{Pa} \cdot \text{cm}^3/\text{s}$ | 11 | 0 | 20 | 6 |
| 9 | High temperature storage | Storage temperature: 85°C t=500 h | 11 | 0 | 20 | 1, 2, 3 |
| 10 | Low temperature storage | Storage temperature: -40°C t=500 h | 11 | 0 | 20 | 1, 2, 3 |
| 11 | High temperature Humid atmosphere storage | Storage temperature: 60°C (Note 2) humidity: 90%RH t=500h | 11 | 0 | 20 | 1, 2, 3 |

Reference Standards : JIS

(Note 1) Soldering position is 1.0mm apart from bottom edge of the case.

(Note 2) To be measured after 72 hours exposure to the room atmosphere.

(Note 3) These test results are sampling examples from a specific lot for reference purpose only, and do not constitute any warranty or assurance in connection with the devices.

4-2 Parameters to be measured and Failure criteria

| No. | Parameters | Failure judgment criteria |
|-----|-------------------|--|
| 1 | Threshold current | $I_{th} > \text{initial value} \times 1.3$ |
| 2 | Operating current | $I_{op} > \text{initial value} \times 1.3$ |
| 3 | Operating voltage | $V_{op} > \text{initial value} \times 1.2$ |
| 4 | Solderability | 95% or more is covered with solder. |
| 5 | Terminal strength | It is defective if there are breaking and loosening. |
| 6 | airtightness | Amount of leak $> 5 \times 10^{-3} \text{Pa} \cdot \text{cm}^3/\text{s}$ |

4-3 Target Lifetime

The target mean time to failure (MTTF) of this product is more than 2,000 h.

MTTF is confirmed by performing the operating test under the following conditions in time of development or change process related to the reliability of this product.

Samples tested should have a laser diode chip with the same structure of this model.

| Conditions | Failure judgment criteria |
|---|---|
| $T_c = 50^\circ\text{C}$, $P_p = 700\text{mW}$, 500 hours (Note 2) | Failure is defined as the time under the operating power under the conditions in the left changes 30% of the initial (12 h) value. (Note 1) As for the samples which do not fail within 500 hours, their life time is calculated by extrapolating operating power data of between 400 and 500 hours. MTTF is estimated by plotting each life time in Weibull function worksheet. (Note 1) |

(Note 1) Defective samples caused by surge current is rejected.

(Note 2) ACC pulse Operation (Pulse Width $0.2 \mu\text{s}$ Duty: 50%)

(Note 3) These test results are sampling examples from a specific lot for reference purpose only, and do not constitute any warranty or assurance in connection with the devices.

Spec No. LH15306A

5. Quality level

- 5-1 Inspection standards ISO 2859 single sampling plan
- 5-2 Method and level extraction Single sampling plan S-2 normal inspection
- 5-3 AQL
- 5-3-1 Definition of the lot the day shipping the product
- 5-3-2 Characteristics

| AQL(%) | Parameter | Failure judgment criteria |
|--------|---|--------------------------------------|
| 1.0 | Ith, Iop, Vop, ηd , λp , $\theta //$, $\theta \perp$, $\Delta \theta //$, $\Delta \theta \perp$ | Not conforming to the specifications |

(Note1) Inspection is performed after blowing.

5-3-3 Appearance

| AQL(%) | Failure judgment criteria |
|--------|--|
| 1.0 | Crack is found on the window glass. Marking is not sufficiently clear to read. Bent lead can not be restored. Impurity or dust its size is over $50\mu m \times 50\mu m$ is found within $1mm\phi$ to the center of the surface of the window glass. (Note.2) |
| 2.5 | There must not be impurity its size is over $50\mu m \times 50\mu m$ that influences the electro-optical characteristics described in specifications. Diameter of stem is not conforming the specification |

(Note2) Inspection is performed after blowing.

6. Supplements

6-1 ODS materials

This product shall not contain the following materials. Also, the following materials shall not be used in the production process for this product.

Materials for ODS : CFCs, Halon, Carbon tetrachloride, 1.1.1-Trichloroethane (Methyl chloroform)

6-2 RoHS compliant product

This product complies with the RoHS Directive (2011/65/EU) and manufactured in accordance with Sharp's Green Device Guidelines.

6-3 Chemical substance information in the product

Product Information Notification based on Chinese law, Management Methods for Controlling Pollution by Electronic Information Products.

Names and Contents of the Toxic and Hazardous Substances or Elements in the Product

| Lead (Pb) | Mercury (Hg) | Cadmium (Cd) | Hexavalent Chromium (Cr(VI)) | Polybrominated Biphenyls (PBB) | Polybrominated Diphenyl Ethers (PBDE) |
|-----------|--------------|--------------|------------------------------|--------------------------------|---------------------------------------|
| ○ | ○ | ○ | ○ | ○ | ○ |

This table was created pursuant to the provisions of SJ / T 11364.

○ : indicates that the content of the toxic and hazardous substance in all the homogeneous materials of the part is below the concentration limit requirement as described in GB/T26572.

× : indicates that the content of the toxic and hazardous substance in at least one homogeneous material of the part exceeds the concentration limit requirement as described in GB/T26572 standard.

Spec No. LH15306A

6-4. Packing

6-4-1. Packing method

- (1) Laser diodes are arranged in a laser tray.
- (2) One tray can accommodate 200 lasers. 5 trays wherein the laser diodes are arranged are stacked up.
- (3) A cover tray is stacked as a cover on the tray wherein the laser diodes are arranged. Stacked trays including a cover are bound with adhesive tape.
- (4) The above bound trays are stuffed into a clean-bag. The bag is sealed by dissolving thermally. One tray can accommodate 200 lasers.
- (5) The trays in the bag are put into a packing case. One packing case can accommodate 2,000 lasers maximum, which is the minimum unit of packing. A Label where in the model number , quantity and lot number are printed is stuck on both of the bag and the case(Refer to 6-4-4).

6-4-2. Materials for packing

| No. | Component parts | Material |
|-----|-----------------|------------------------------|
| 1 | Laser tray | conductive polystyrene resin |
| 2 | Cover tray | conductive polystyrene resin |
| 3 | Clean-bag | anti - static plastic |
| 4 | Packing case | cardboard |
| 5 | shock absorber | anti - static polyetyrene |

6-4-3. External appearance of packing

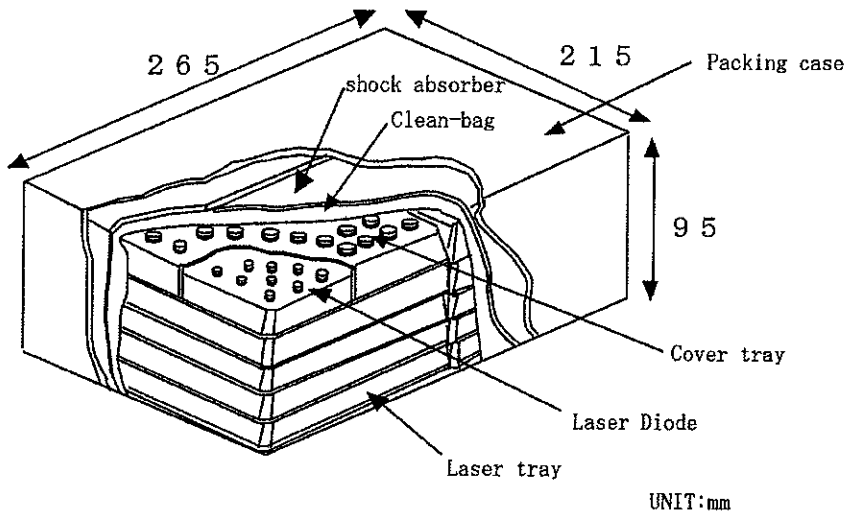

6-4-4. Label

(1) A label on the clean-bag

| | |
|------|---------------------|
| TYPE | Model name (Note 2) |
| Q'TY | 1000 |
| LOT | Lot No. |

SHARP CORPORATION
MADE IN ****(Note 1)

R.C.
(Note 3)

(2) A label on the packing case

| | |
|------|---------------------|
| TYPE | Model name (Note 2) |
| Q'TY | 2000 |
| LOT | Lot No. |

SHARP CORPORATION
MADE IN ****(Note 1)

R.C.
(Note 3)

(Note 1) ****:Production country

(Note 2) A management number in the factory is written in (), if the product produced in a factory except Japan.

(Note 3) This identification mark shows the settlement product for RoHS designed by using a green material based on our green device guideline.

Spec No. LH15306A

7. Operating and handling precautions

- (1) This product has its life. The product life which is described in "Reliability" should be taken into account when using it.
- (2) This product will be damaged by electrostatic discharge (ESD). Following precautions should be taken to avoid ESD damage.
 - ⇒ Workers, workbenches and other equipment should always be grounded. Workers should always wear an antistatic wrist strap and an antistatic smock on them.
 - ⇒ When handling this product, workers should always wear antistatic gloves or finger covers.
 - ⇒ A stable DC power supply which is free from electrical transients should always be used when operating this product. A slow starter circuit should always be inserted between the power supply and this product in order to protect it from DC power surges.
 - ⇒ Optical power output of this product should be set with a highly reliable and high quality variable resistance.
 - ⇒ This product should always be connected to the driving circuit by soldering directly or through highly reliable connectors.
 - ⇒ While this product is being operated, be sure to avoid touching the driving circuit or the terminals of this product with electrical probes from a synchroscope or a voltmeter.
 - ⇒ An antistatic package should be used when storing this product.
The recommended preservation is stored in the tray and the clean-bag in an environmental condition dry at normal temperature (0~40°C)
 - ⇒ This product should be processed in the rooms where relative humidity is kept at 50-70%RH.
- (3) Because the adhesion of garbage and dust to the window glass might disarrange an optical characteristic of this product, maintain the work room to cleanness so as not generate dust, please.
- (4) In this Product, generation of heat happens in the laser chip because of operating. The case temperature rises by this generation of heat. Because the rise of the case temperature becomes a factor to shorten the lifetime of this product, a sufficient heat sink should be attached to this product when operating so that its case temperature is to be maintained at the same level as that of the surrounding.
- (5) Even if the drive current supply has an automatic power control (APC), automatic current control (ACC), or both, be sure to monitor the optical power output with an optical power meter while setting it. Never estimate the optical power output only from the drive current because it is likely to be decreased by temperature rise of the surrounding.
- (6) When dirt adheres to the window glass of this product, please wipe lightly with the cotton bud that adheres the ethanol.
- (7) The window glass cracks easily because it is thin. Therefore, please avoid putting the load on the cap, for example clumping, tightens, or fixing to the treatment device hard.
- (8) This product consists of a hermetic package, in which the blue violet laser diode chip is mounted. The blue violet laser diode chip will be easily damaged by air, moisture or etc. So when the package dose not keep hermetically, the lifetime of this product will be remarkably shorten.
Following precautions should be taken to avoid destroying the hermetic package.
 - ⇒ The window glass cracks easily because it is thin. Therefore, please do not give the mechanical shock such as falls, and please avoid applying the stress to the cap, for example clumping, tightening hard, or fixing to the treatment device.
 - ⇒ Because applying the overstress to the lead pin or repeating to bend the lead pin at its bottom, will destroy the hermetic seal. Please do not apply the overstress to the base part of lead pin.
 - ⇒ When a large stress is applied to the package, please confirm whether the package is kept hermetically before using this product.
- (9) Although the beam emitted by this laser diodes will be harmful to the human eyes. So the following precautions should be taken.
 - ⇒ When this product is being operated, the emitting surface of a chip should not be viewed either directly or through a lens, microscope or optical fibers.
 - ⇒ When operating this product, wear safety glasses.
- (10) When soldering this product, heat lead pins only using a soldering iron in short time. Avoid heat the whole package using pre-heat or reflow soldering.